

R C R B D

RECORD SET

PJ2716-1
Fire Prevention
 In: 11/06/2017
 Out: 11/08/2017

GENERAL NOTES

- Column repair to address sloping beams and roof.
- Remove existing stone veneer around columns and inspect for suspected rot/deterioration on base of existing GL columns.
- Level and shore existing beams, remove lower portion of GL column and replace with new column base.
- All existing framing member sizes shown shall be field verified by contractor at time of construction.
- All dimensions shown shall be field verified by contractor at time of construction.
- Contractor shall notify engineer of discrepancies between field conditions and those shown on drawings prior to construction.
- Contractor's option, in lieu of tall column base provide 1'-4" x 1'-4" grouted CMU pier w/ (4) #4 verticals doweled into existing footing and column base w/ height to match thickness of cap stone.

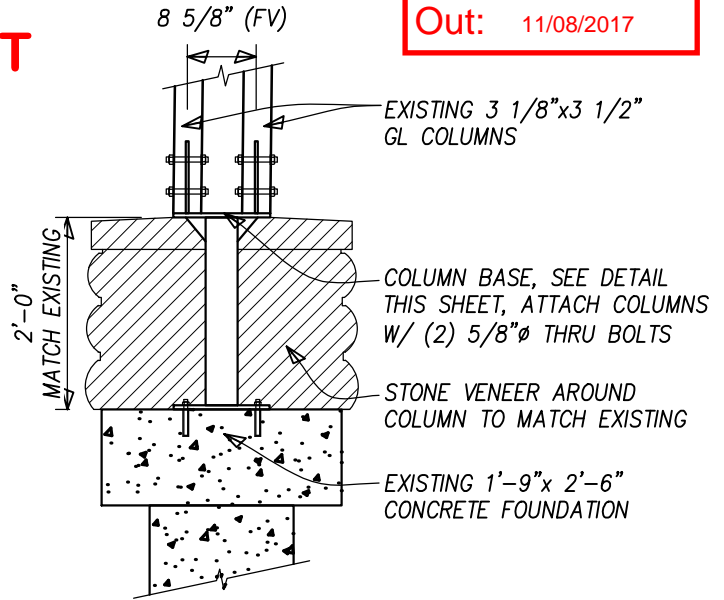

PIER/COLUMN DETAIL

1/2" = 1'-0"

STRUCTURAL STEEL

- Structural steel rolled shapes shall conform to ASTM A572, Grade 50. Plates and angles shall conform to ASTM A36. Tube shapes shall conform to ASTM A500 Grade B., 46 ksi yield. Pipe shapes shall conform to ASTM A53, Grade B.
- All bolts shall conform to ASTM Specification A307.
- All welding shall be done by a certified welder.

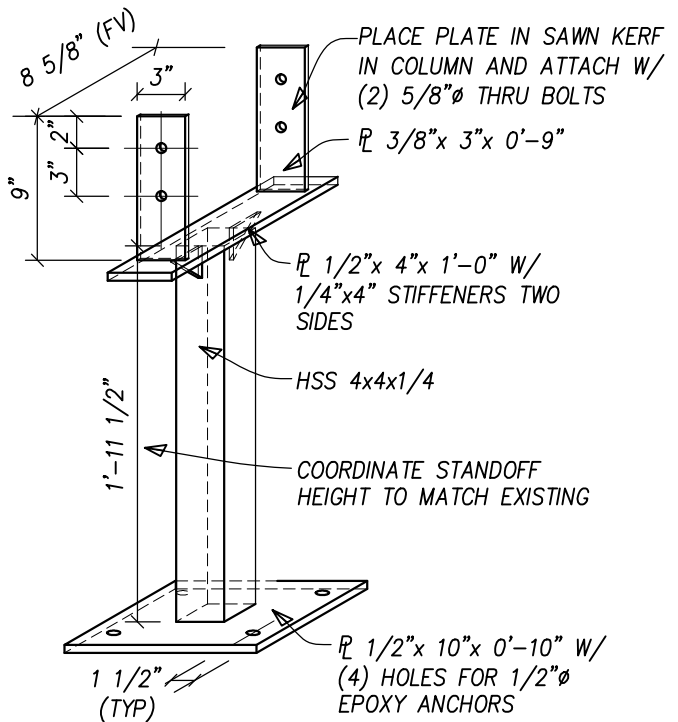

COLUMN BASE

1" = 1'-0"

EPOXY ADHESIVE ANCHORING SYSTEM

- Epoxy adhesive anchoring system shall be Hilti HIT-RE 500 or approved equal.
- Anchor rods shall be furnished with chamfered ends so that either end will accept a nut and washer and meet the requirements of ISO 898 Class 5.8.
- Anchors shall have the following minimum embedments: 3/4" diameter - 6 3/4", 5/8" diameter - 5 5/8", 1/2" diameter - 4 1/2".

STRUCTURAL ERECTION AND BRACING REQUIREMENTS

- The Contractor, in the proper sequence, shall provide proper shoring and bracing as may be required during construction to achieve the final completed structure.

HERITAGE PARK SCHOOL

COLUMN/BASE DETAILS

COLUMN REPAIR
 27285 BRANDON CIRCLE
 STEAMBOAT SPRINGS, COLORADO 80487

DATE	10-16-17
PROJECT	#17-098
DRAWN	BFS
CHECKED	BFS
FILE	.dwg
SCALE	AS NOTED

ALPENGLOW
 ENGINEERING SOLUTIONS, INC.
 Consulting Structural Engineers

IF YOU ARE NOT THE ORIGINAL CONTRACTOR, PLEASE SIGN TO VERIFY ACCURACY OF INFORMATION.

SHEET

S-1

1 OF 1